

HDSRM™ 150TC

Powerful. Sustainable. Lightweight



No rare earth magnets	Lower cost, improved sustainability and reduced supply chain risk compared to permanent magnet (PM) motors.
No copper windings	Patented aluminium winding technology offering lower mass, with no loss of performance, and a uniquely recyclable solution.
Off-the-shelf power electronics	Unlike conventional switched reluctance motors, HDSRM runs with any suitable, commercially-available 3-phase inverter.
Designed for volume manufacture	UK production line, capable of building high volume for global customers.
Efficient where it counts	Design optimized to be more efficient than a PM or induction motor at normal commercial vehicle operating points.
Air cooled	Designed for simplicity with no pipes, no water, no radiator and no pump.
Small and lightweight	Our most lightweight motor designed especially for light commercial vehicle and trailer driven systems.
Robust and reliable	Built for improved robustness, HDSRM is more fault tolerant and has safer failure modes.

Parameter	Performance
Torque	100Nm for 155Arms
Power (Peak/Continuous)	50kW / 25kW @ 700VDC
Efficiency	>96% at peak
Mass	<30kg

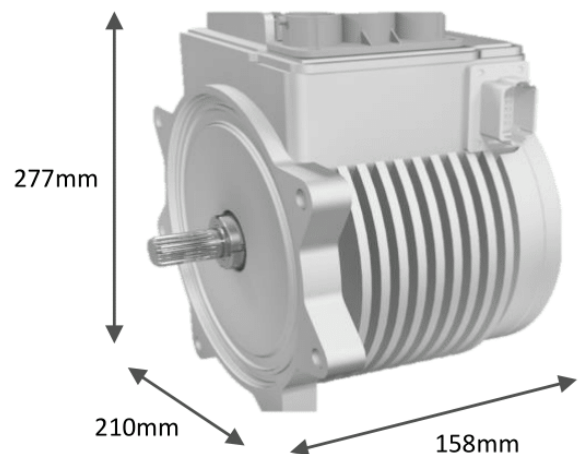

All specifications are subject to change without notice